

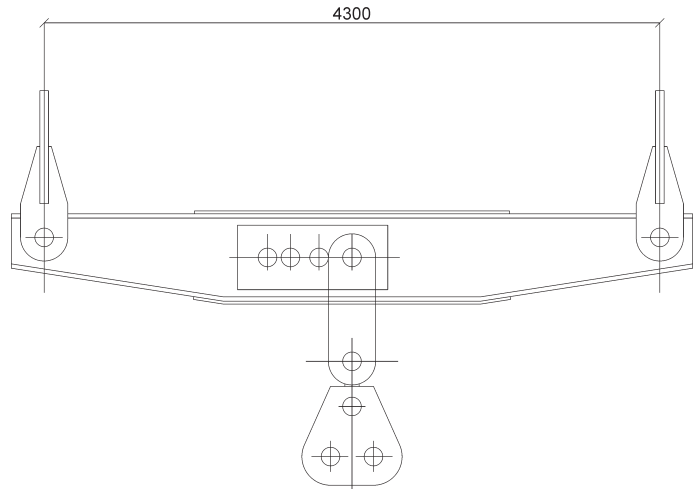

## Traverse 1

Tragfähigkeit 120,0 t  
Eigengewicht 3,5 t



## Traverse 2

Tragfähigkeit 100,0 t  
Eigengewicht 1,5 t

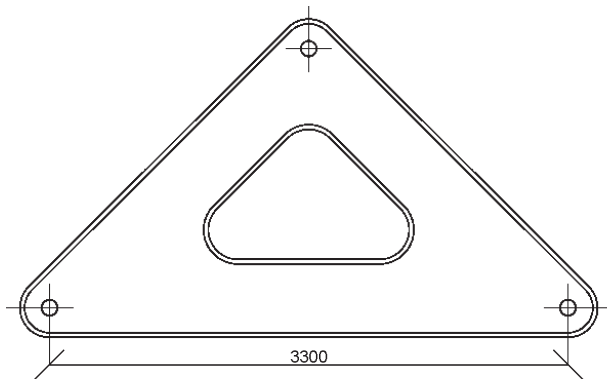

## Traverse 3

Tragfähigkeit 100,0 t  
Eigengewicht 1,6 t

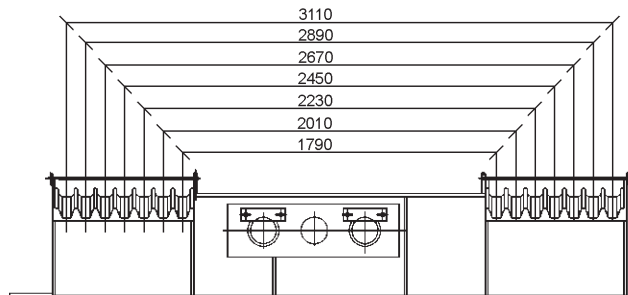



## Traverse 4

Tragfähigkeit 80,0 t  
Eigengewicht 1,7 t

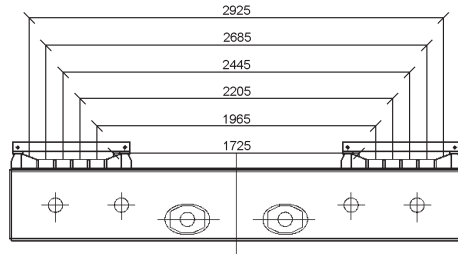

## Traverse 5

Tragfähigkeit 30,0 t  
Eigengewicht 0,7 t

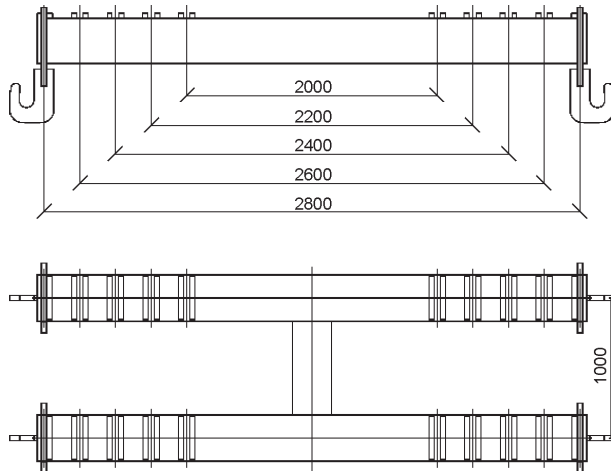

## Traverse 6

Tragfähigkeit 25,0 t  
Eigengewicht 1,2 t

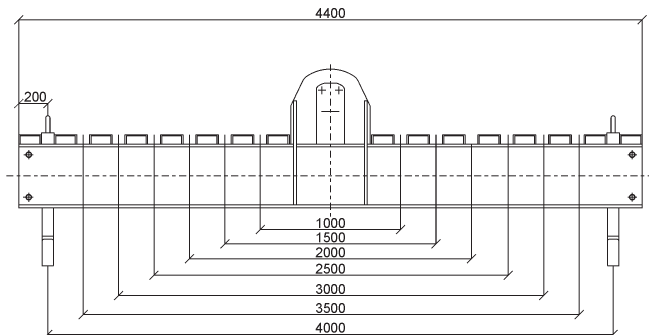



## Traverse 7

Tragfähigkeit 20,0 t  
Eigengewicht 0,8 t

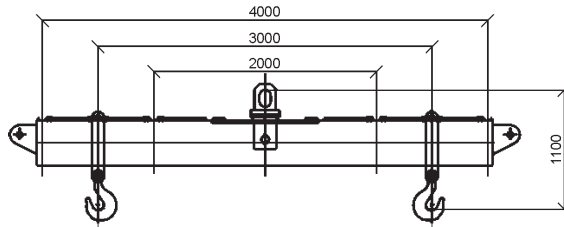

## Traverse 8

Tragfähigkeit 4,5 t  
Eigengewicht 0,33 t

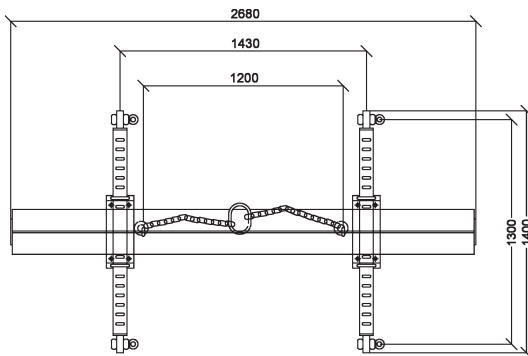

## Traverse 9

Tragfähigkeit 25,0 t  
Eigengewicht 1,2 t

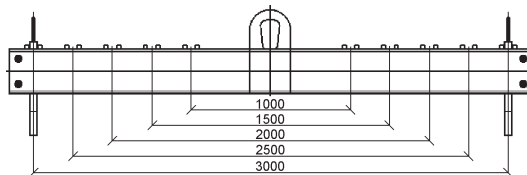

## Traverse 10

Tragfähigkeit 15,0 t  
Eigengewicht 0,6 t

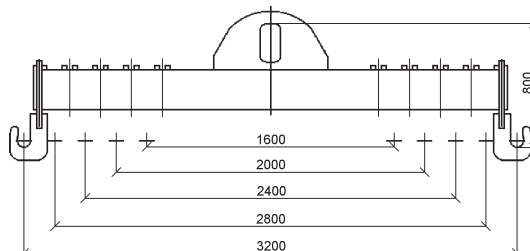



## Traverse 11

Tragfähigkeit 10,0 t  
Eigengewicht 1,5 t

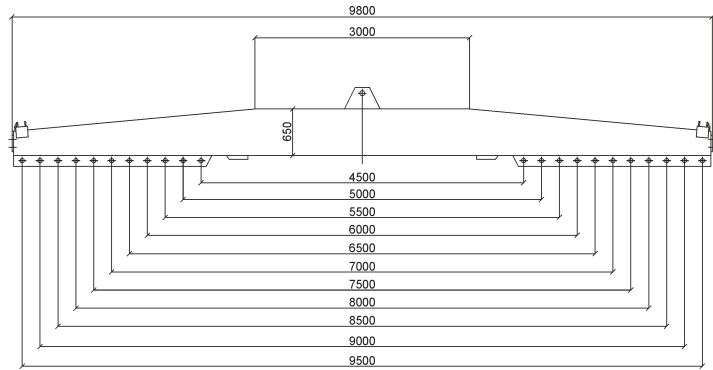

## Traverse 12

Tragfähigkeit 10,0 t  
Eigengewicht 1,0 t

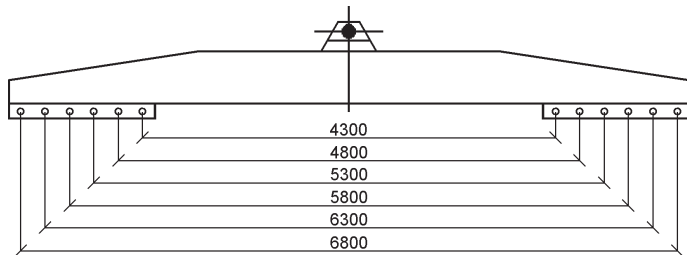

## Traverse 13

Tragfähigkeit 10,0 t  
Eigengewicht 0,3 t

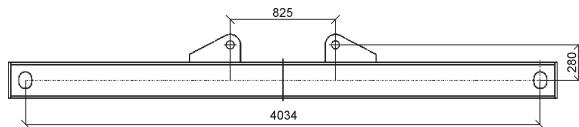

## Traverse 14

Tragfähigkeit 5,0 t  
Eigengewicht 0,7 t

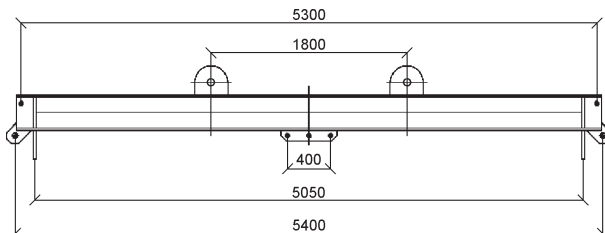



## Traverse 15

Tragfähigkeit 8,0 t  
Eigengewicht 0,7 t

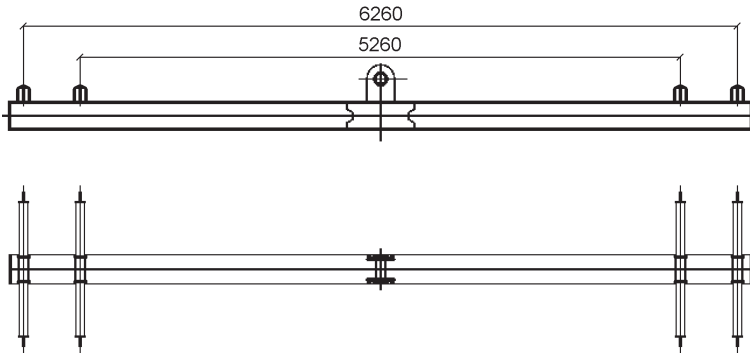

## Traverse 16

Tragfähigkeit 10,0 t  
Eigengewicht 0,3 t

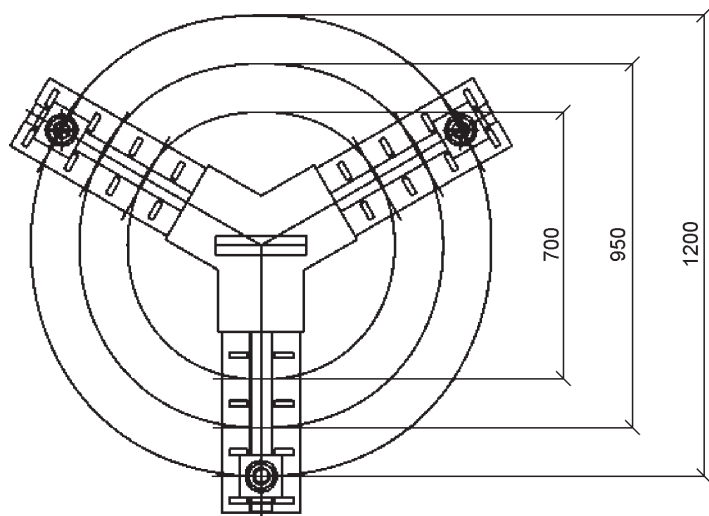



## Traverse 17

Tragfähigkeit 6,0 t  
Eigengewicht 0,15 t

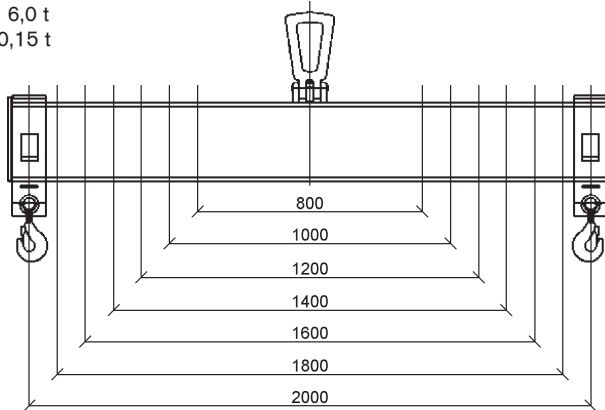

## Traverse 18

Tragfähigkeit 5,0 t  
Eigengewicht 0,2 t

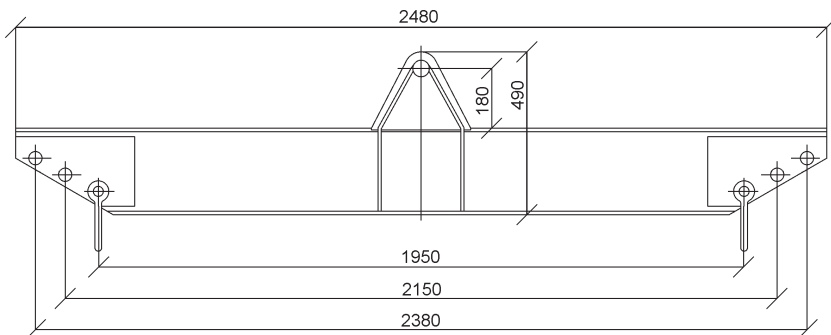

## Traverse 19

Tragfähigkeit 4,0 t  
Eigengewicht 0,1 t

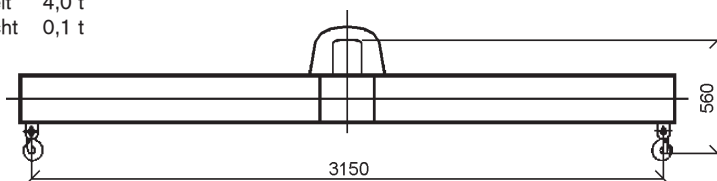



## Traverse 20

Tragfähigkeit 25,0 t  
Eigengewicht 0,2 t  
Anhängeweite 2,76 m

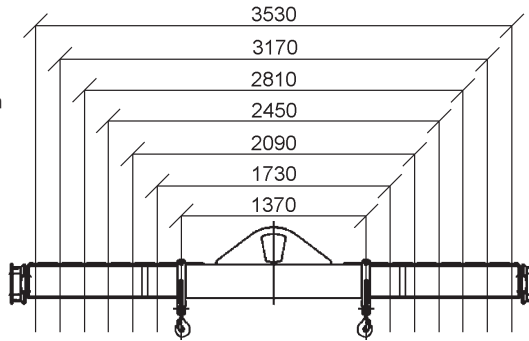

## Traverse 21

Tragfähigkeit 100,0 t  
Eigengewicht 3,6 t

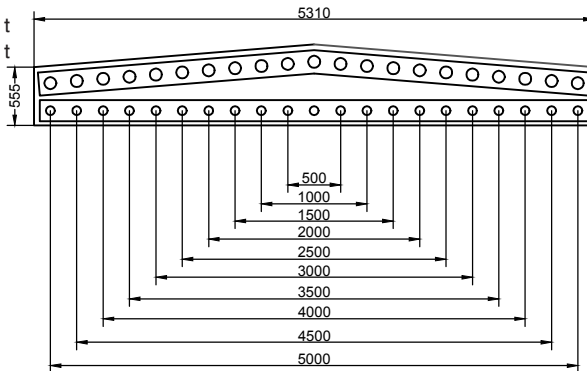

## Spreize 22

für Sidra-Schäkel, Typ HA2  
max. Länge 27180 m  
min. Länge 1180 m  
Variable Anhängeweiten und Gewichte auf Anfrage

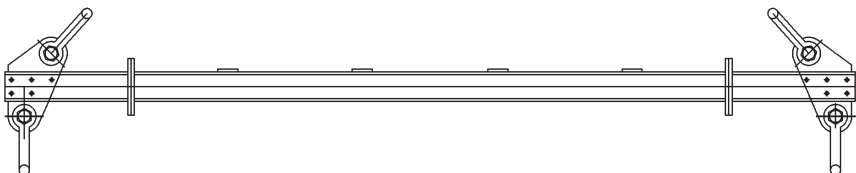



## Spreize 23

Tragfähigkeit 20,0 t  
Eigengewicht 0,4 t

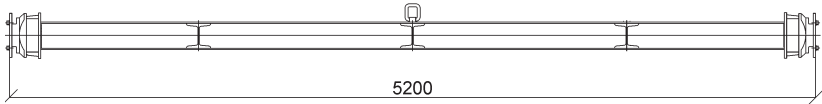

## Spreize 24

Tragfähigkeit 20,0 t  
Eigengewicht 0,15 t

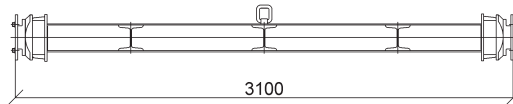

## Spreize 25

Tragfähigkeit 20,0 t  
Eigengewicht 0,1 t

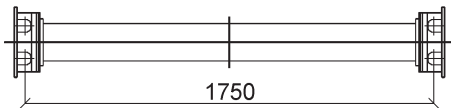

## Spreize 26

Tragfähigkeit 20,0 t  
Eigengewicht 0,1 t

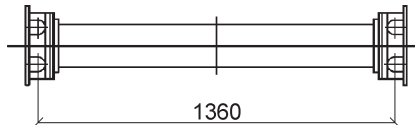

## Traverse 27

Tragfähigkeit 20,0 t  
Eigengewicht 0,3 t

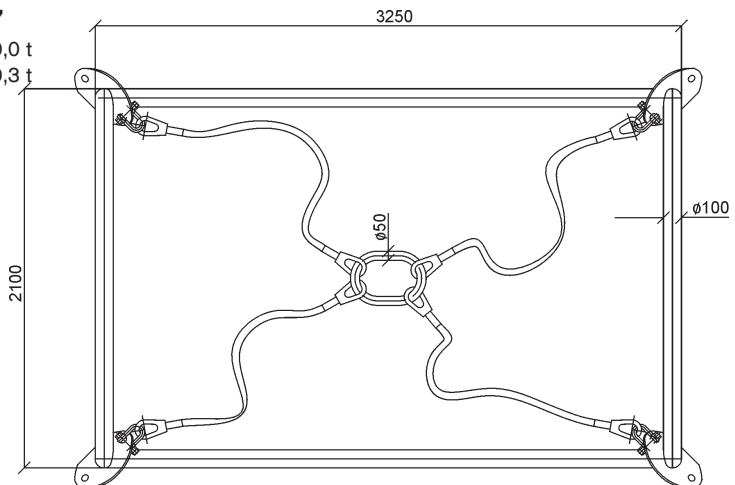



## Traverse 28

Tragfähigkeit 30,0 t  
Eigengewicht 0,3 t

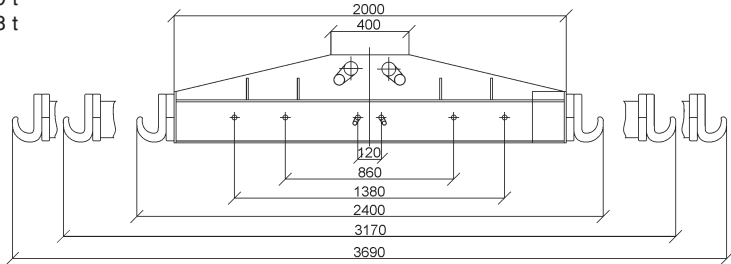

## Traverse 29

Tragfähigkeit 10,0 t  
Eigengewicht 0,1 t

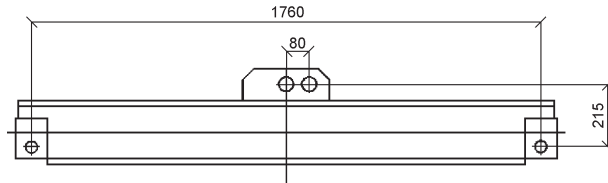

## Spreize 30

Tragfähigkeit 25,0 t  
Eigengewicht 0,2 t

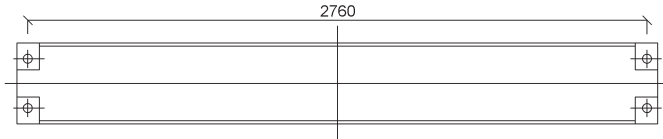

## Traverse 32

Tragfähigkeit 10,0 t  
Eigengewicht 0,4 t

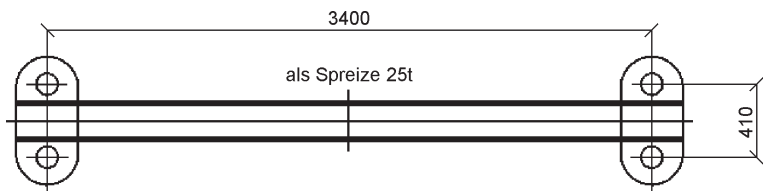



## Traverse 33

Tragfähigkeit 10,0 t

Eigengewicht 0,4 t

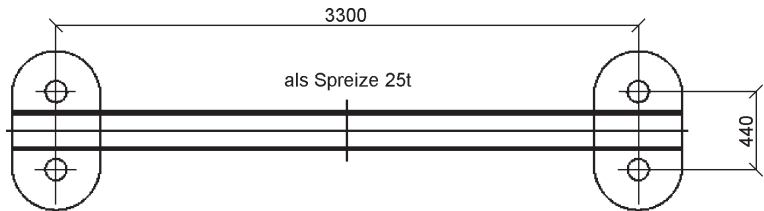

## Traverse 34

Tragfähigkeit 5,0 t

Eigengewicht 0,2 t

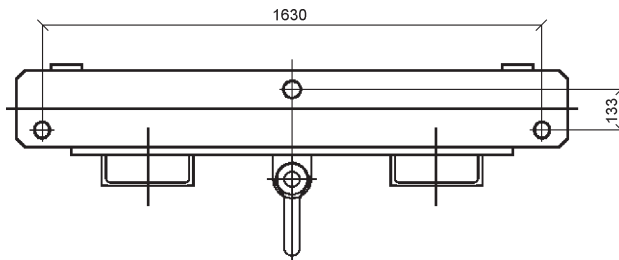

## Traverse 35

Tragfähigkeit 0,5 t

Eigengewicht 0,1 t

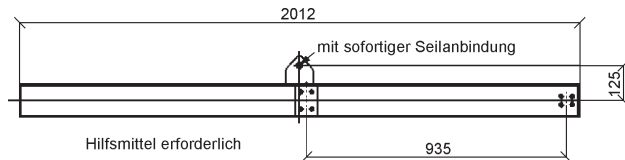

## Traverse 37

Tragfähigkeit 5,0 t

Eigengewicht 0,3 t

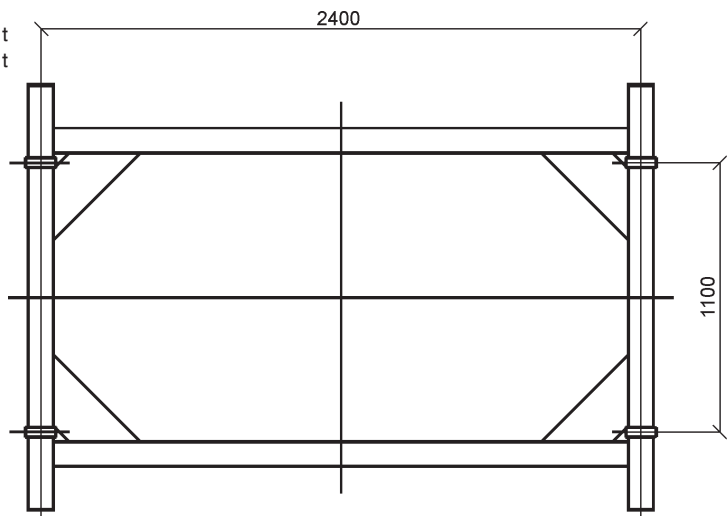



## Spreize 38

Tragfähigkeit 20,0 t  
Eigengewicht 0,35 t

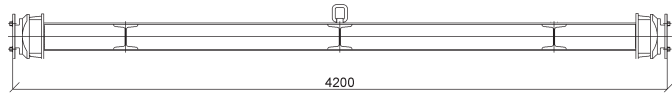

## Traverse 39

Tragfähigkeit 20,0 t  
Eigengewicht 0,4 t

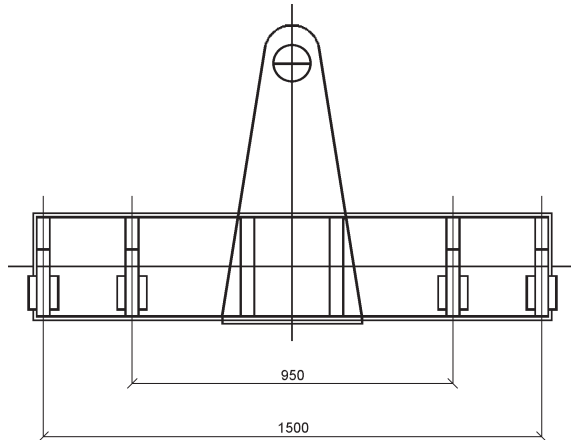

## Traverse 42

Tragfähigkeit 30,0 t  
(mehr auf Anfrage)  
Eigengewicht 2,2 t

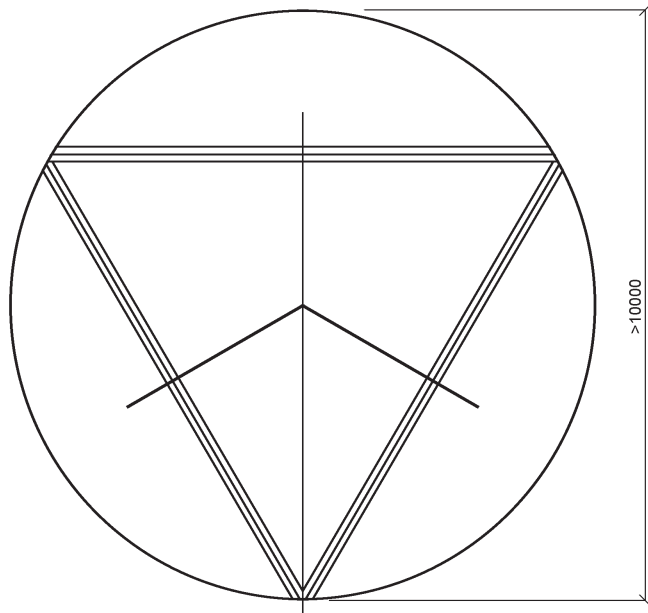



## Traverse 43

Tragfähigkeit 30,0 t  
(mehr auf Anfrage)  
Eigengewicht 1,9 t  
(bei 8600 x 3700)

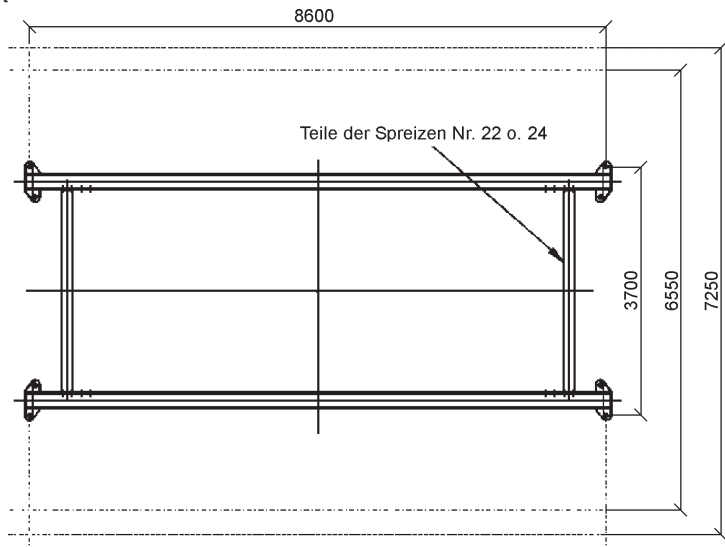

## Spreize 44

Tragfähigkeit 20,0 t  
Eigengewicht 3,0 t

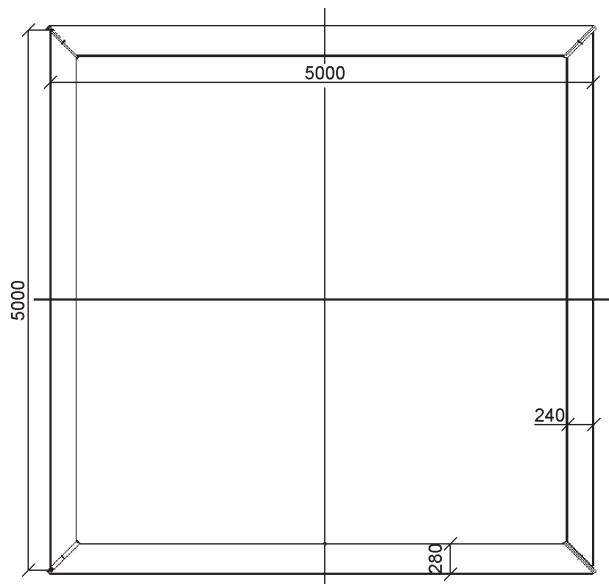



## Traverse 45

Tragfähigkeit 16,0 t  
Eigengewicht 2,2 t

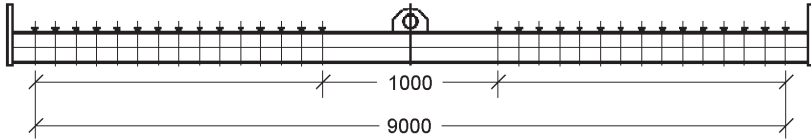

## Traverse 46

Tragfähigkeit 10,0 t  
Eigengewicht 0,2 t

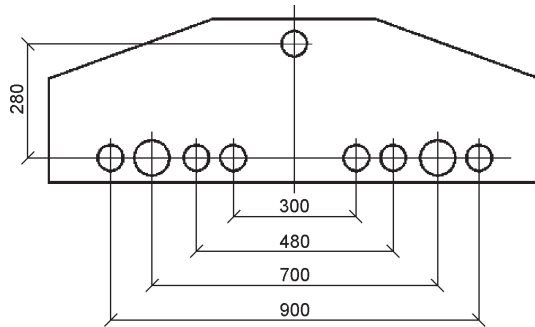

## Traverse 47

Tragfähigkeit 60,0 t  
Eigengewicht 0,5 t

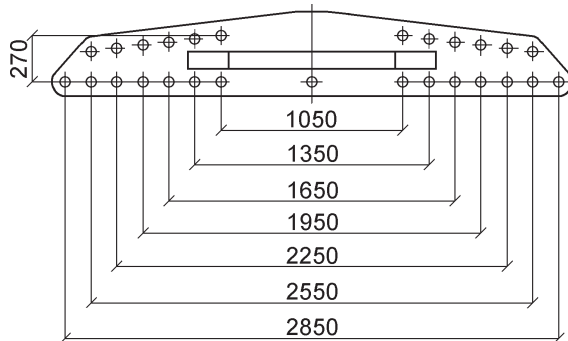

## Traverse 49

Tragfähigkeit 30,0 t  
Eigengewicht 0,1 t

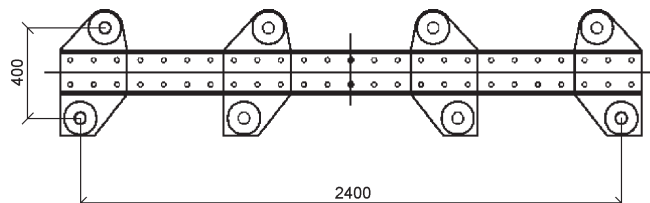



## Traverse 51

Tragfähigkeit 16,0 t  
Eigengewicht 1,4 t

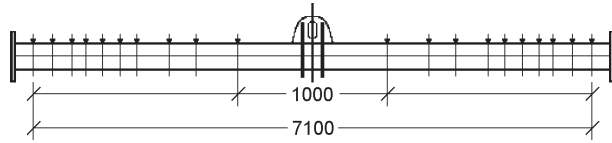

## Traverse 52

Tragfähigkeit 20,0 t  
Eigengewicht 2,7 t

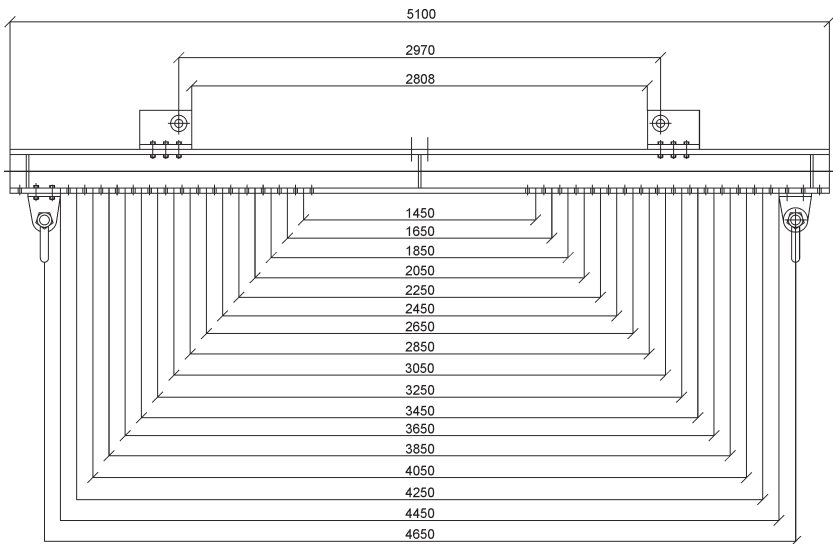

## Traverse 53

Tragfähigkeit 15,0 t  
Eigengewicht 0,285 t

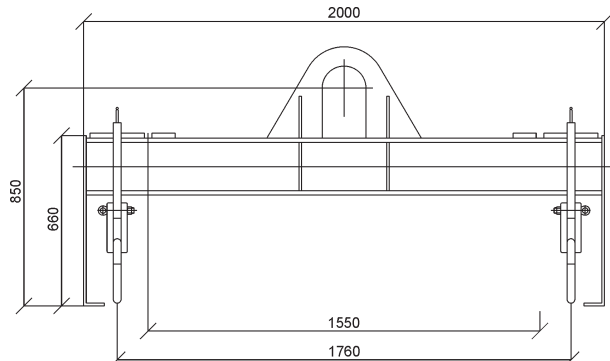



## Traverse 54

Tragfähigkeit 30,0 t  
Eigengewicht 0,18 t

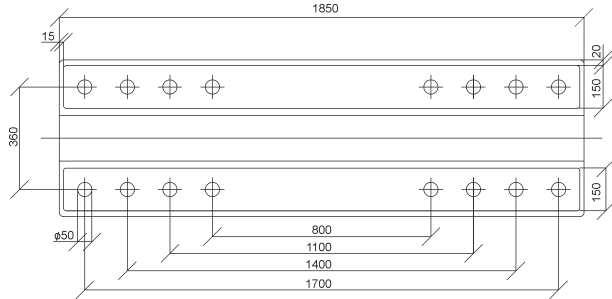

## Traverse 55

Tragfähigkeit 10,0 t  
Eigengewicht 0,75 t

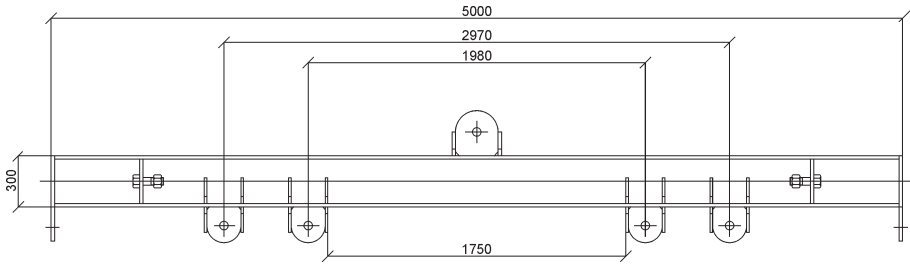

## Traverse 56

Tragfähigkeit 6,0 t  
Eigengewicht 0,16 t

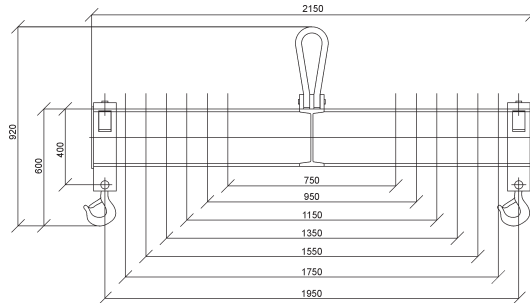

## Traverse 57

Tragfähigkeit 5,0 t  
Eigengewicht 0,28 t

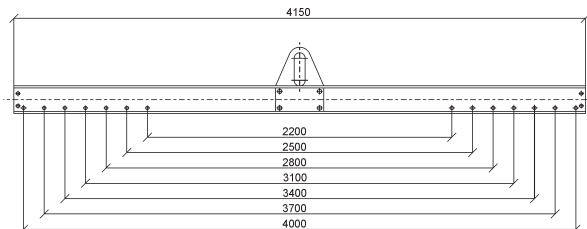



## Traverse 58

Tragfähigkeit 40,0 t

Eigengewicht 3,2 t

Variable Anhängeweiten und Gewichte auf Anfrage

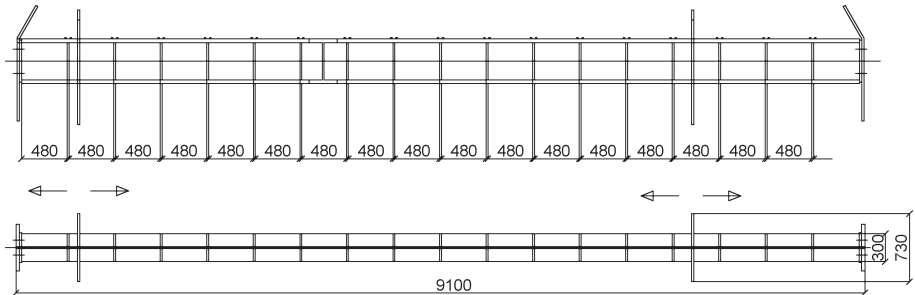

## Traverse 59

Tragfähigkeit 15,0 t

Eigengewicht 0,38 t

