



Industriekran 60 t

Terex A 600

COLONIA
SPEZIALFAHRZEUGE

559

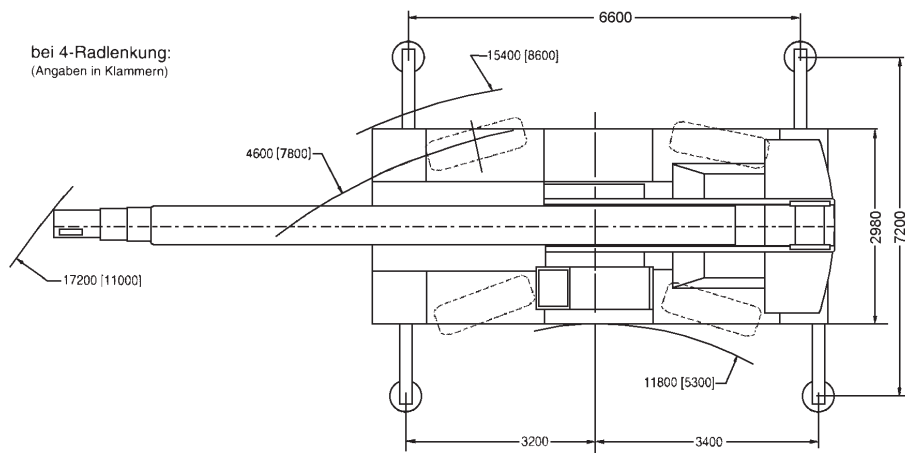
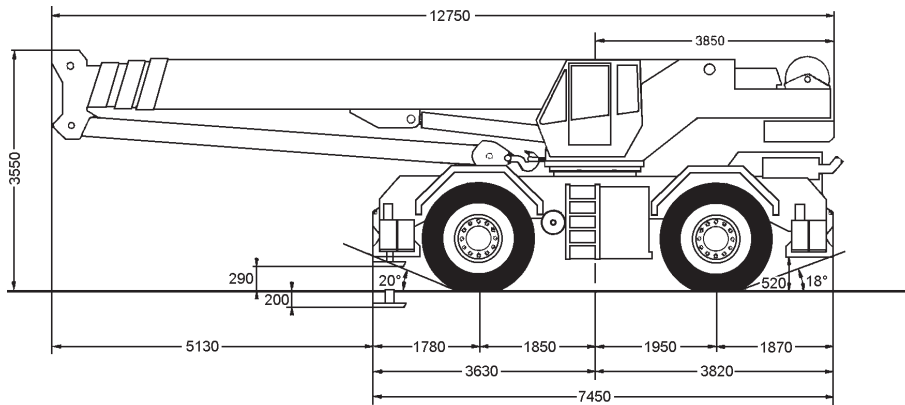

Traglasten für reduzierte Abstützung auf Anfrage

Industriekran 60 t





Die Arbeitsbereiche

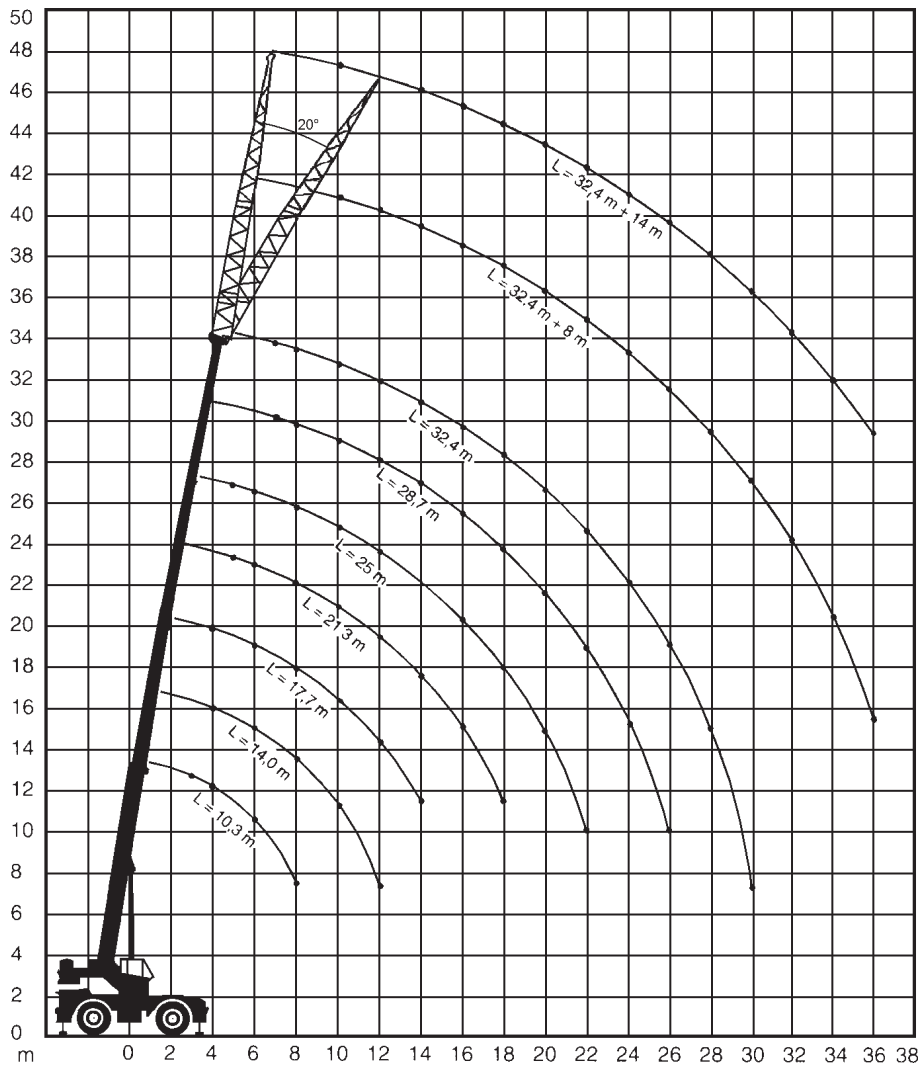

Terex A 600

Industriekran 60 t



COLONIA
SPEZIALFAHRZEUGE

561





	10,3	14	17,7	21,3	25	28,7	32,4	
3	55							3
4	43,2	39,2	33,8					4
5	34	34	28,5	24,7	19,9			5
6	27,5	27	25,5	21,8	18,1	15,5		6
7	23,4	23	21,5	19	16,4	14,4	11,7	7
8	19	18,8	18,6	16,9	14,7	13,1	11	8
9		17	16,8	14,7	13,4	12,3	10,6	9
10		14	13,8	13,5	12,1	11,2	9,6	10
12			9,7	9,7	9	9,5	8,2	12
14			6,8	7,2	7,2	7,1	7,1	14
16				5,8	5,8	5,8	5,8	16
18				4,5	4,5	4,4	4,3	18
20					3,6	3,4	3,7	20
22					2,3	2,8	3,1	22
24						2,6	2,8	24
26						2	2,3	26
28							1,8	28
30							1,5	30



Industriekran 60 t





	10,3	14	17,7	21,3	25	
3	22,1					3
3,5	19,4					3,5
4	17,15					4
4,5	15,25					4,5
5	13,7	12,4				5
6	11,7	10,95				6
7	10,15	9,05	8,9			7
8	8,25	8,15	7,65			8
9		6,5	6,1	6,55		9
10		5,35	4,9	5,4	5,35	10
12		3,5	3,25	3,65	3,6	12
14			2,05	2,35	2,3	14
16				1,55	1,5	16
18				1	0,95	18



	10,3	14	17,7	21,3	25	
4,5	13,65					4,5
5	12,25	12				5
6	10,15	9,9				6
7	8,5	8,25	8,05			7
8	7,2	6,95	6,75			8
9		5,9	5,7	6,05		9
10		5	4,85	5,15	5,35	10
12		3,5	3,25	3,65	3,6	12
14			2,05	2,35	2,3	14
16				1,55	1,5	16
18				1	0,95	18





Industriekran 60 t

Terex A 600

564

COLONIA
SPEZIALFAHRZEUGE



32,4m



8m



7,2x6,6m





8,7t



360°



75%

	8		
	0°	20°	
8	6,5		8
10	5,9	3,2	10
12	5,3	3	12
14	4,8	2,9	14
16	4,3	2,8	16
18	3,9	2,7	18
20	3,3	2,6	20
22	2,75	2,3	22
24	2,05	2,05	24
26	1,65	1,6	26
28	1,3	1,3	28
30	1	1	30
32	0,7	0,7	32



32,4m



14m



7,2x6,6m





8,7t



360°



75%

	14		
	0°	20°	
10	3,3		10
12	3		12
14	2,7	1,6	14
16	2,5	1,5	16
18	2,3	1,45	18
20	2,1	1,4	20
22	1,9	1,35	22
24	1,75	1,3	24
26	1,6	1,25	26
28	1,3	1,1	28
30	1,1	1,05	30
32	0,65	0,7	32